

KIT FEATURES

- ▶ Works with factory brackets or Metra's 99-8101
- ▶ Fills space left after removing double-DIN unit



88-00-8000 AW-800PKUV INSTALLATION INSTRUCTIONS

APPLICATIONS

<u>CAR</u>	<u>PAGE</u>
TOYOTA	
4Runner 1984-88.....	1
4Runner 1989-95.....	1
4Runner 1996-99.....	2
Camry 1987-91.....	2
Celica (GT/GTS) 1986-89.....	3
Celica 1990-93.....	3
Corolla (GTS/SR5) 1984-87.....	4
Corolla (sedan/wagon-lower dash) 1988-92.....	4
Corolla (sedan/wagon-upper dash) 1988-92.....	5
Corolla (coupe-lower dash) 1993-97.....	5
Corolla (coupe-upper dash) 1993-97.....	6
MR2 1991-94.....	6
Pickup 1984-88.....	7
Pickup 1989-91.....	7
Pickup 1992-95.....	8
Supra 1986-92.....	8
T100 1993-98.....	9
Tacoma 1995-00.....	9

KIT COMPONENTS

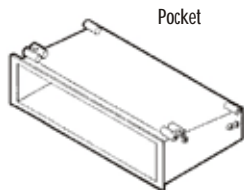

TOOLS REQUIRED



Phillips screwdriver



Cutting tool

1-800-221-0932 www.metraonline.com

© COPYRIGHT 2001 METRA ELECTRONICS CORPORATION



USE THE FOLLOWING INSTRUCTIONS FOR APPLICATIONS USING FACTORY BRACKETS. FOR APPLICATIONS USING METRA'S 99-8101, USE THE INSTRUCTIONS PROVIDED WITH THAT KIT.

TOYOTA 4Runner 1984-88

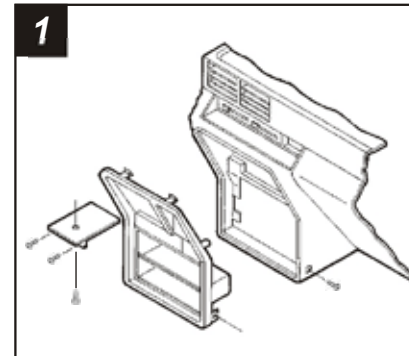

Disconnect the negative battery terminal to prevent an accidental short circuit. Remove the ashtray and (3) screws from the ashtray bracket. Remove (1) screw from each side of the dash console and unsnap the trim bezel.

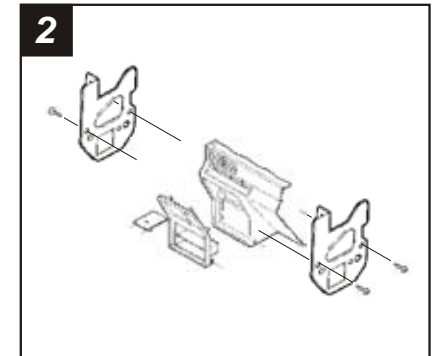

Remove the mounting brackets from the factory head unit assembly. Align the holes in the mounting brackets with the holes in the **Pocket**. Mount the factory mounting brackets to the **Pocket** with those screws previously removed.

TOYOTA 4Runner 1989-95

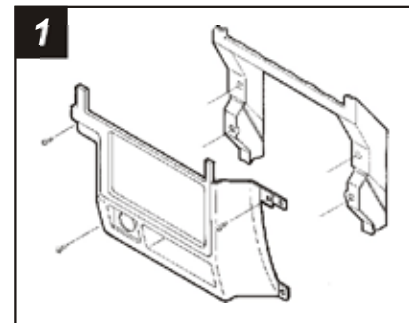

Disconnect the negative battery terminal to prevent an accidental short circuit. Remove the driver's side speaker panel by removing (3) screws and (1) 10mm bolt. Remove (1) screw from the left side of the housing and unsnap the ignition cover. Remove the glove compartment assembly by removing (1) 10mm bolt from the bottom of the speaker panel and (3) screws from the right side of the housing. Remove the remaining (3) screws securing the radio trim bezel.

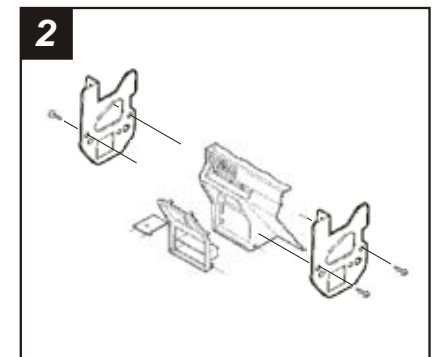

Remove the mounting brackets from the factory head unit assembly. Align the holes in the mounting brackets with the holes in the **Pocket**. Mount the factory mounting brackets to the **Pocket** with those screws previously removed.

TOYOTA 4Runner 1996-99

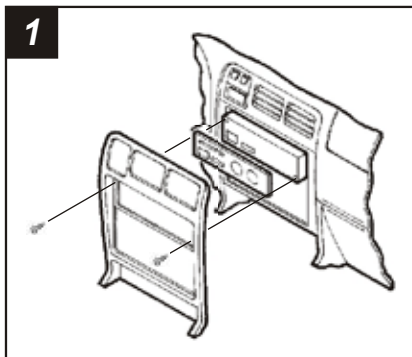

1
Disconnect the negative battery terminal to prevent an accidental short circuit. Open the center armrest door. Unsnap the parking brake trim panel to access the gear shifter trim panel. Unsnap the gear shifter trim panel and remove. Remove the climate control knobs. Remove the climate control trim plate and (2) Phillips screws exposed. Unclip the radio trim bezel and remove. Remove (4) Phillips screws securing the factory head unit and disconnect the wiring.

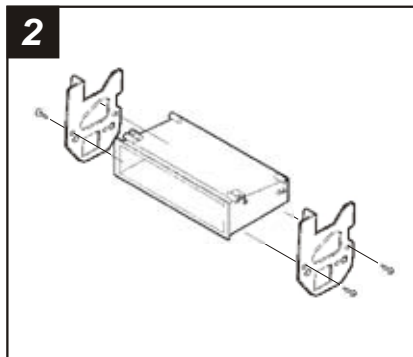

2
Remove the mounting brackets from the factory head unit assembly. Align the holes in the mounting brackets with the holes in the **Pocket**. Mount the factory mounting brackets to the **Pocket** with those screws previously removed.

TOYOTA Celica (GT/GTS) 1986-89

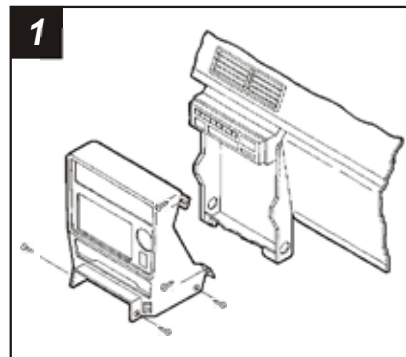

1
Disconnect the negative battery terminal to prevent an accidental short circuit. Remove (2) screws from the lower steering column panel and remove. Remove the (2) screws exposed on the radio trim bezel. Open the glove box and remove (1) screw and (1) bolt exposed. Remove (2) screws from the ashtray cavity and (2) screws from the bracket. Remove (2) screws from each lower side of the trim bezel and unsnap the bezel.

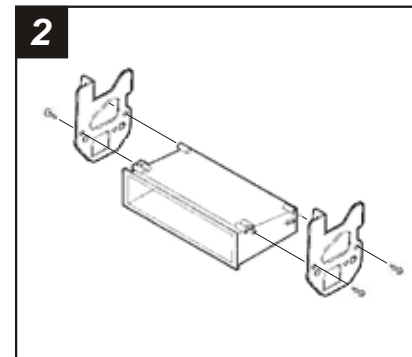

2
Remove the mounting brackets from the factory head unit assembly. Align the holes in the mounting brackets with the holes in the **Pocket**. Mount the factory mounting brackets to the **Pocket** with those screws previously removed.

TOYOTA Camry 1987-91

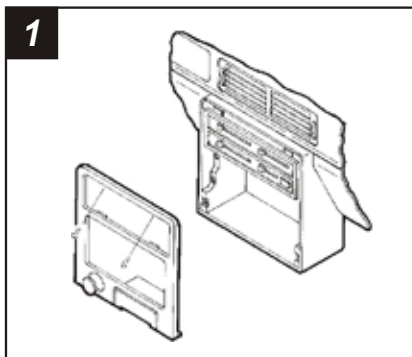

1
Disconnect the negative battery terminal to prevent an accidental short circuit. Remove (2) screws above the climate controls and gently unsnap the dash trim bezel. Remove (4) screws securing the factory head unit and disconnect the wiring.

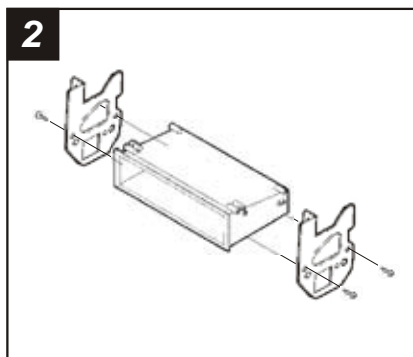

2
Remove the mounting brackets from the factory head unit assembly. Align the holes in the mounting brackets with the holes in the **Pocket**. Mount the factory mounting brackets to the **Pocket** with those screws previously removed.

TOYOTA Celica 1990-93

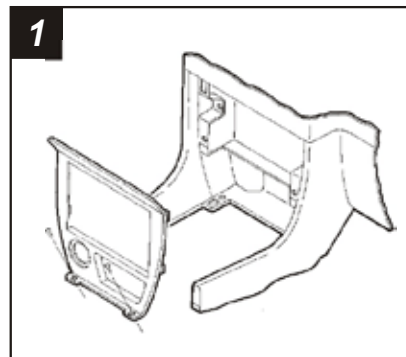

1
Disconnect the negative battery terminal to prevent an accidental short circuit. Carefully pry up on the gear shifter trim panel and remove. Remove (2) screws exposed on the bottom edge of the radio trim panel. Unsnap the panel and disconnect the ashtray and cigarette lighter wiring.

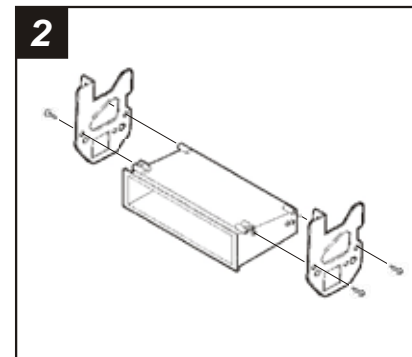

2
Remove the mounting brackets from the factory head unit assembly. Align the holes in the mounting brackets with the holes in the **Pocket**. Mount the factory mounting brackets to the **Pocket** with those screws previously removed.

TOYOTA Corolla (GTS/SR5) 1984-87

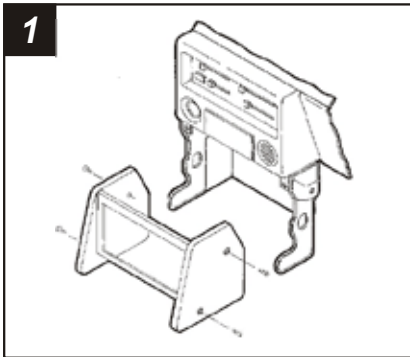

1
Disconnect the negative battery terminal to prevent an accidental short circuit. Remove (2) Phillips screws from each side of the console trim bezel. Remove (4) screws securing the factory head unit and disconnect the wiring.

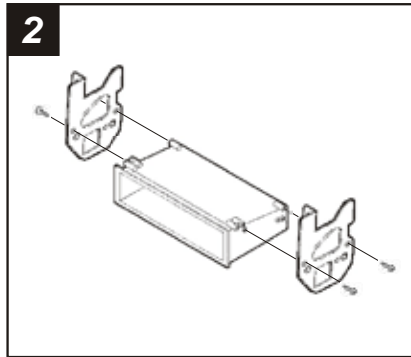

2
Remove the mounting brackets from the factory head unit assembly. Align the holes in the mounting brackets with the holes in the **Pocket**. Mount the factory mounting brackets to the **Pocket** with those screws previously removed.

TOYOTA Corolla (sed/wag-upper dash) 1988-92

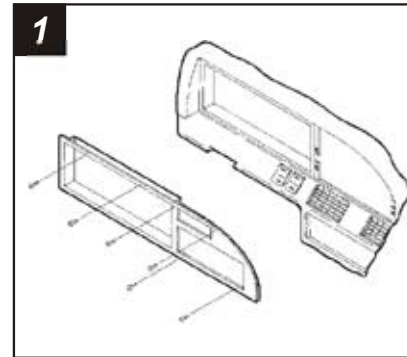

1
Disconnect the negative battery terminal to prevent an accidental short circuit. Remove (4) screws from the top edge of the instrument trim bezel and (2) screws below the radio opening. Remove (1) screw from the lower-left tab of the bezel (to the right of the a/c vent) and unsnap the bezel.

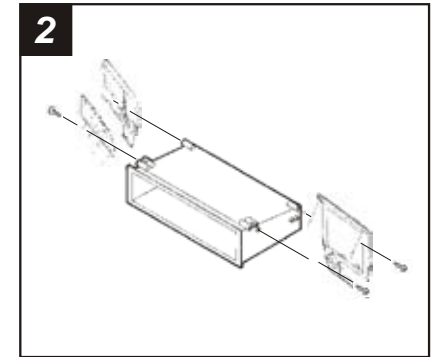

2
Remove the mounting brackets from the factory head unit assembly. Align the holes in the mounting brackets with the holes in the **Pocket**. Mount the factory mounting brackets to the **Pocket** with those screws previously removed.

TOYOTA Corolla (sed/wag-lower dash) 1988-92

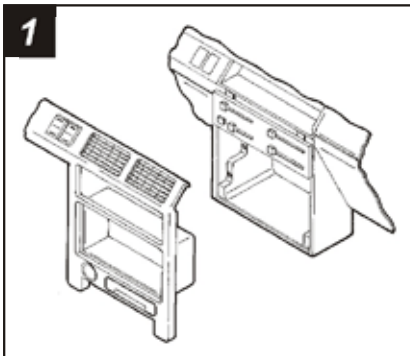

1
Disconnect the negative battery terminal to prevent an accidental short circuit. Remove (1) screw located to the right of the ignition switch. Remove (1) screw located above the driver's side speaker. Carefully unsnap the dash trim bezel (some force may be required).

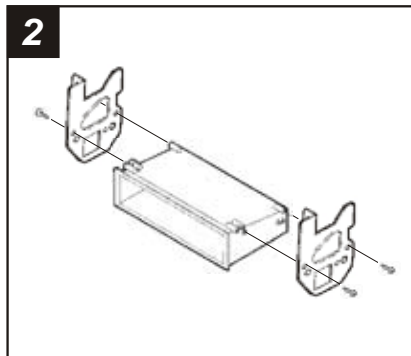

2
Remove the mounting brackets from the factory head unit assembly. Align the holes in the mounting brackets with the holes in the **Pocket**. Mount the factory mounting brackets to the **Pocket** with those screws previously removed.

TOYOTA Corolla (coupe-lower dash) 1993-97

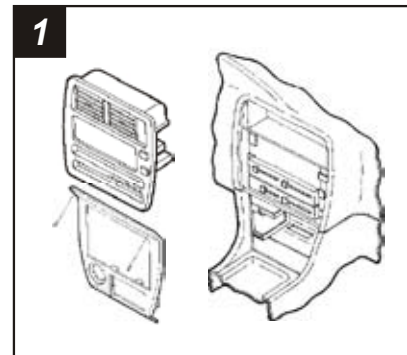

1
Disconnect the negative battery terminal to prevent an accidental short circuit. Remove the climate control knobs, unsnap the upper trim bezel and disconnect the hazard and clock leads. Remove (2) screws from the lower trim bezel and remove.

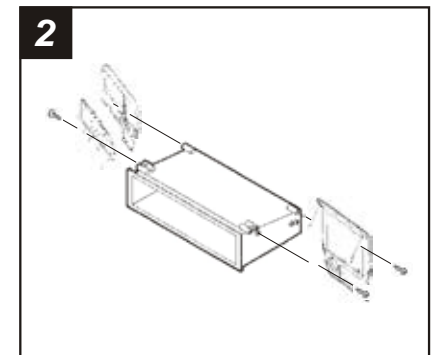

2
Remove the mounting brackets from the factory head unit assembly. Align the holes in the mounting brackets with the holes in the **Pocket**. Mount the factory mounting brackets to the **Pocket** with those screws previously removed.

TOYOTA Corolla (coupe-upper dash) 1993-97

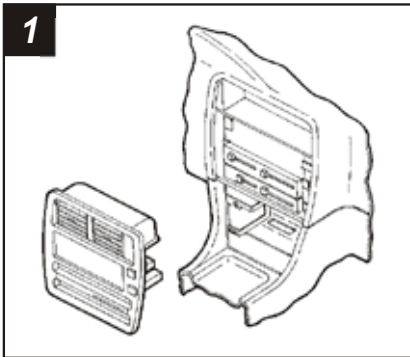

1
Disconnect the negative battery terminal to prevent an accidental short circuit. Remove the climate control knobs and unsnap the dash trim bezel. Disconnect the clock and hazard leads.

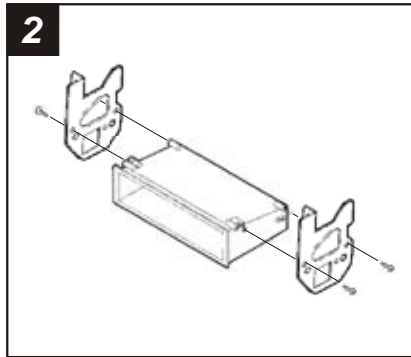

2
Remove the mounting brackets from the factory head unit assembly. Align the holes in the mounting brackets with the holes in the **Pocket**. Mount the factory mounting brackets to the **Pocket** with those screws previously removed.

TOYOTA Pickup 1984-88

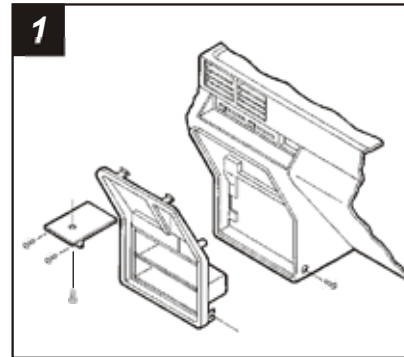

1
Disconnect the negative battery terminal to prevent an accidental short circuit. Remove the ashtray and (3) screws from the ashtray bracket. Remove (1) screw from each side of the dash console and unsnap the trim bezel.

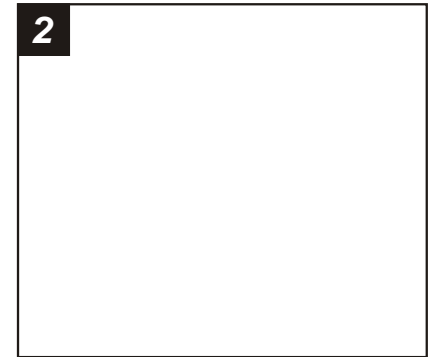

TOYOTA MR2 1991-94

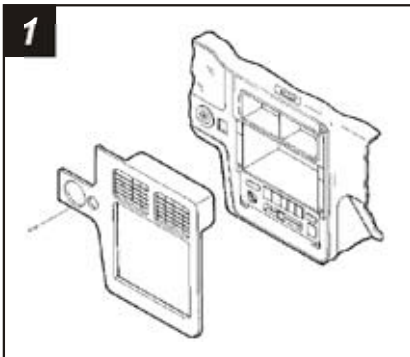

1
Disconnect the negative battery terminal to prevent an accidental short circuit. Remove the ashtray and (2) screws from the ashtray cavity. Unsnap and remove the shifter console bezel. Remove (1) screw below the ignition switch and remove the dash trim bezel.

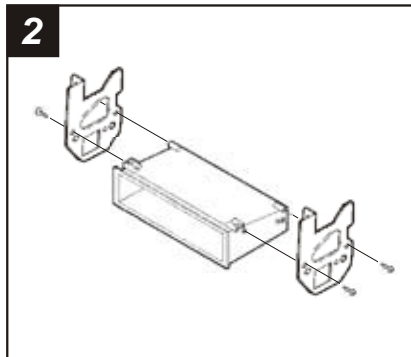

2
Remove the mounting brackets from the factory head unit assembly. Align the holes in the mounting brackets with the holes in the **Pocket**. Mount the factory mounting brackets to the **Pocket** with those screws previously removed.

TOYOTA Pickup 1989-91

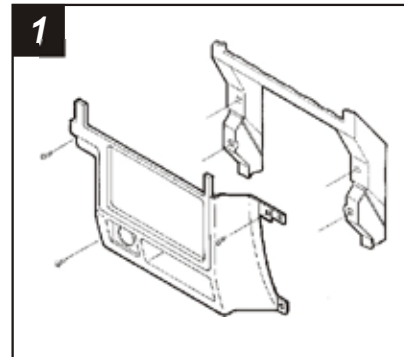

1
Disconnect the negative battery terminal to prevent an accidental short circuit. Remove the driver's side speaker panel by removing (3) screws and (1) 10mm bolt. Remove (1) screw from the left side of the housing and unsnap the ignition cover. Remove the glove compartment assembly by removing (1) 10mm bolt from the bottom of the speaker panel and (3) screws from the right side of the housing. Remove the remaining (3) screws securing the radio trim bezel.